

# BRANDEL



AUTOMATED ADHESIVE PLATE SEALING SYSTEMS

# WHY CHOOSE A BRANDEL PLATE SEALING SYSTEM?

---

BRANDEL plate sealers provide a pressure-based sealing solution, thus eliminating the drawbacks that occur when using a heat-based plate sealer.

BRANDEL plate sealers apply a uniform adhesive seal using a variety of tapes, with most any plate configuration, height, design or composition.

All plate sealers can be used as a stand-alone unit.

Brandel plate sealers require no compressed air, vacuum, etc.

Model available for integration into liquid handling and robotic systems.





## SEALING TAPES

---

### **BREATHABLE** (Catalog# 9791)

Gas permeable tape consisting of a white rayon, non-woven backing, coated on one side with a pressure-sensitive acrylate adhesive. Tape is supplied on a white paper release liner.

### **ALUMINUM** (Catalog# 9792)

Single coated tape consisting of an aluminum seal coated with pressure-sensitive acrylate adhesive. Easy to pierce with a metal probe or a plastic pipette. Tape is supplied on a brown paper release liner.

### **POLYESTER** (Catalog# 9794)

Single coated tape consisting of a translucent polyester film with pressure sensitive acrylate adhesive. Tape is supplied on a white paper release liner.

### **ADVANCED POLYOLEFIN** (Catalog# 9795)

Transparent polyolefin film with clear, pressure sensitive, low silicone adhesive. Best choice for visual microscopic analysis. Supplied on a white polyester release liner.

### **CLEAR** (Catalog# 9800)

Costs only pennies per seal. Ideal for crystallography.

*Please contact Brandel to discuss any questions, special requests, and/or requirements regarding sealing tapes.*

# SEALER SPECIFICATIONS

Electrical: 100-240V / 50-60Hz

Dimensions: See Below

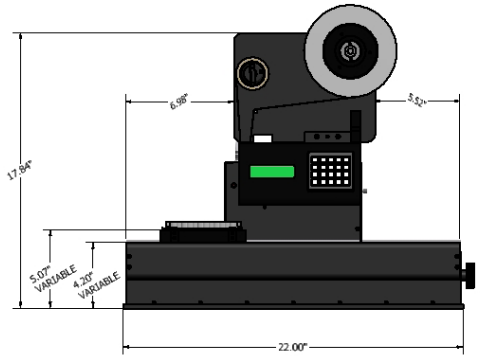
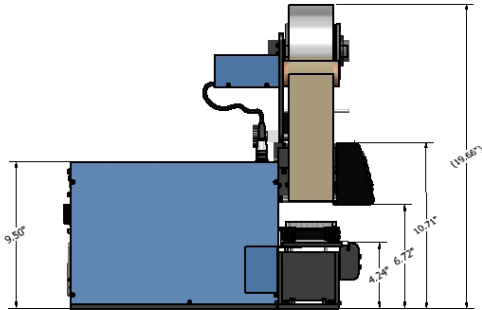
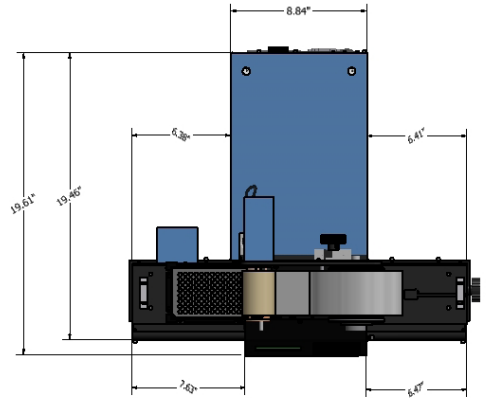

## SEMI-AUTOMATED SYSTEM

Catalog# CS-2000

## FULLY-AUTOMATED SYSTEM WITH RS-232 INTERFACE

Catalog# RS-3000

Includes RS-232 interface, making it the ideal component for integration into liquid handling and robotic systems.

## FULLY-AUTOMATED SYSTEM (RS-3000) WITH PLATE STACKER

Catalog# RS-4000

# FEATURES & CAPABILITIES

---

- Programmable software allows for up to 9 different sealing profiles to be stored and recalled from memory
- Sealing process and tape cutting is fully automated
- Ability to adjust the beginning and the end of the tape seal
- Adjustable sealing pressure
- Ability to adjust tape roll location in order to insure proper width placement onto specific plates
- Ability to set plate position height prior to the sealing process
- Adjustable tape roll assembly facilitates usage with various tape diameters, tensions and materials
- Adjustable plate carriage allows for sealing of multiple plate designs
- Ability to set start position of plate (either left or right side)

# ***BRANDEL***

---

**Building Equipment to Meet Your Needs**

BRANDEL, INC

8561 Atlas Drive, Gaithersburg, MD 20877 USA

Telephone: 800-948-6506 | Fax: 301-869-5570

sales@brandel.com | www.brandel.com